

1. Overview

The CPC Cathodic Protection Controller uses a microprocessor running embedded software to achieve the required operation. Specific hardware has been designed to fulfil different input and output requirements of an industrial charge controller while maintaining a cost effective solution. The CPC Software is the same for various specific solutions.

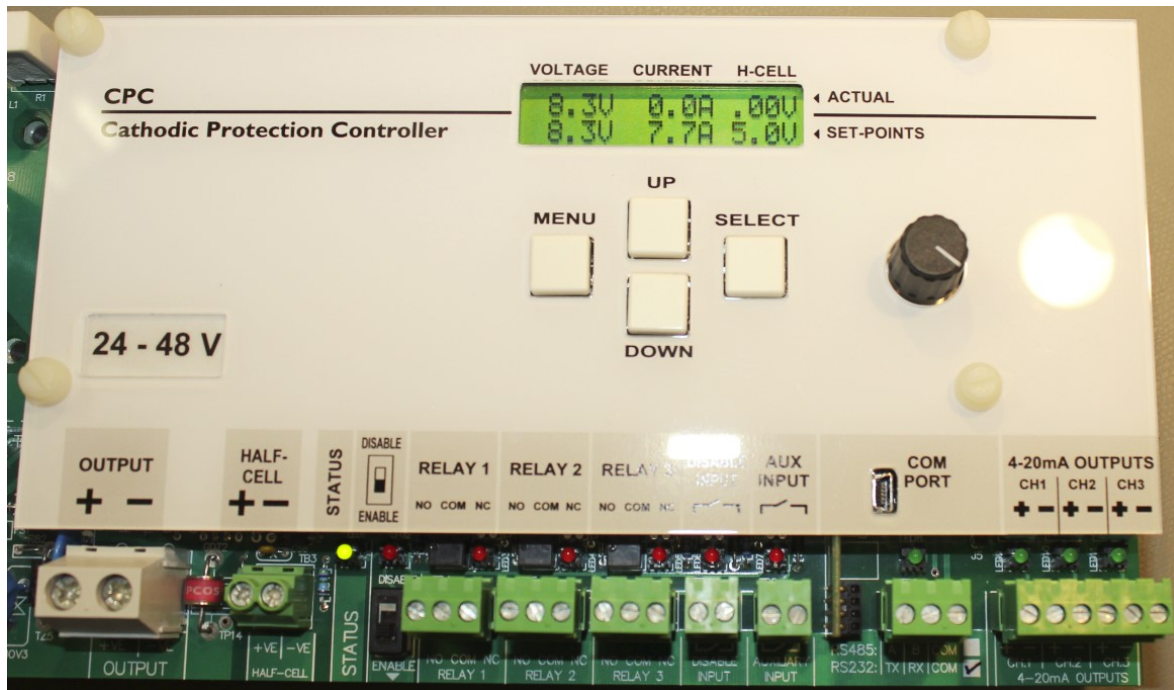

Quick Start Guide:	Make it work quickly!	Section 2
	Simple steps to get the controller powered up and working	
General Operation:	How does the Controller it work?	Section 3
	Explanation of the operation and functions available	
Information Screens:	What information is available?	Section 4
	Information available to the user on the LCD Display	
Software History:	What changed from the last version?	Section 5
	Why and how the software has evolved over time	

Previous versions of Software may not have all the features described in this Manual

2. Quick Start Guide

2.1. System Concept

Cathodic Protection (CP) works by passing current through 'ground'. It is essential that the system Common (the Positive potential) is only grounded at the output of the CP Controller. If a ground connection is made at any other point in the system, it is possible that the CP Controller will not be able to monitor or control the output current and voltage correctly, particularly if a reference electrode is used.

The following diagram shows a simple connection drawing of a Cathodic Protection System:

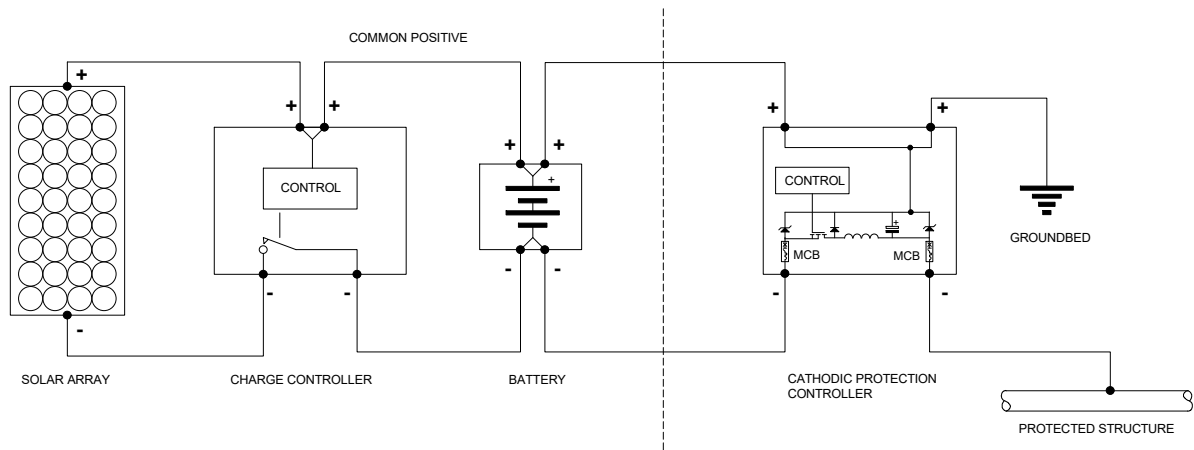

Grounding of Enclosures

The grounding of enclosures and structures is acceptable, but under no circumstances should a connection be made from the system common to a metal enclosure or structure otherwise the protective current is liable to have an adverse effect on these parts, and in some cases may accelerate corrosion.

2.2. Reference Electrode (Half-Cell)

The Reference Electrode is also referred to in this manual as the Half-Cell. A diagram of how a Half-Cell should be connected is shown below. Note that for protection of the structure, the potential of the structure should be at a lower potential than the Ground-bed. Although this may be considered a negative voltage, only the value of the Half-Cell voltage is shown on the display; i.e. if the connections have been made as shown below then the Structure connection to the Half-Cell input will be more negative than the Positive connection to the Half-Cell, and the value of that potential will be shown on the display.

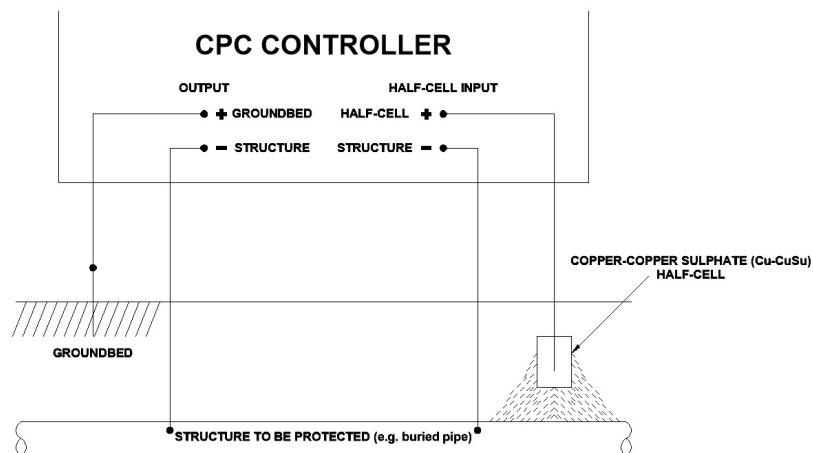

2.3. System Connections:

- 2.3.1. Connect the Battery to the CPC Input Power connections
- 2.3.2. Connect the CPC Output connections to the Ground-bed and the Structure
- 2.3.3. Connect the Reference Electrode (if required)
- 2.3.4. Connect any Signal Cables for monitoring (as required)

2.4. System Power On:

- 2.4.1. Ensure the Switch on the CPC Control PCB Assembly is in the Disable position
- 2.4.2. Turn on the Battery using whatever disconnect device is provided in the system
- 2.4.3. Adjust the Output Voltage Control to 0.0V
- 2.4.4. Adjust the Output Voltage Control the desired current limit
- 2.4.5. Adjust the Half-Cell Control to 5.0V
- 2.4.6. Ensure the Switch on the CPC Control PCB Assembly is in the Enable position

3. CPC General Operation

The CPC Controller is designed to be connected to a battery and is a power converter which will apply impressed current onto a structure in order to inhibit corrosion.

The controller is designed for industrial use in high ambient temperature applications.

3.1. CPC Controller Features

- Measurement of Input Voltage, Output Voltage, Output Current, Half-Cell Voltage
- CPC Voltage, Current, Half-Cell Voltage Control Algorithm
- Volt-Free Alarm Relay Outputs & Volt-Free Digital Input to connect to other equipment
- 3 x 4-20mA Outputs to signal other equipment
- Communications Port to allow data communications to other equipment
- High & Low Output Current Alarms
- High & Low Input Voltage Alarms
- High & Low Output Voltage Alarms
- Enable / Disable switch on CPC Control PCB Assembly

4. CPC Information Screens

The CPC Controller has a 2-line by 16-character alphanumeric LCD Display which is used to display system information and settings to the user.

Screens available to the user are shown on the following **Menu Map**:

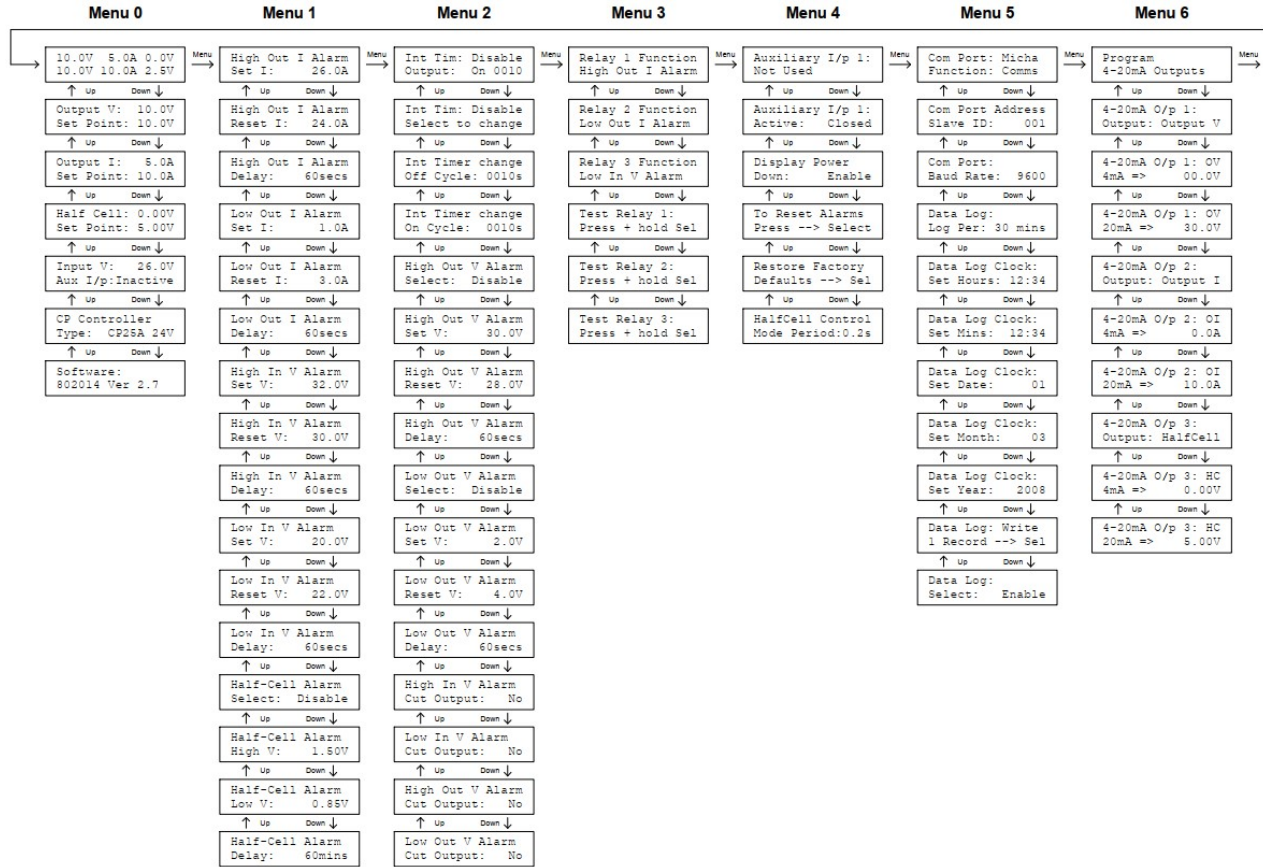

4.1. Menu Navigation

Menu keypad switch moves the user along the Menus 0 to 6 and back to Menu 0.

Up and **Down** keypad switches moves the user up and down within a Menu.

Select keypad switch activates functions or selects a parameter to change its value.

Pressing **Menu** and **Down** switches at the same time will move the user to **Menu 0 Screen 0**.

Menu 0 Screen 0 is also called the **Home Screen**.

4.2. Menu 0 – System Information

Menu 0	Screen	Description
10.0V 5.0A 0.0V 10.0V 10.0A 2.5V	0	Output Voltage, Output Current, Half-Cell Voltage - Actual Values Output Voltage, Output Current, Half-Cell Voltage - Set-Points
Output V: 10.0V Set Point: 10.0V	1	Output Voltage Actual Value Output Voltage Set-Point adjust
Output I: 5.0A Set Point: 10.0A	2	Output Current Actual Value Output Current Set- Point adjust
Half Cell: 0.00V Set Point: 5.00V	3	Half-Cell Voltage Actual Value Half-Cell Voltage Set- Point adjust
Input V: 26.0V Aux I/p:Inactive	4	Input Voltage Actual Value Auxiliary Input Status: Active or Inactive
CP Controller Type: CPC25A 24V	5	CP Controller Identification Screen CP Controller Model and System Voltage
Software: 802014 Ver 2.7	6	Microcontroller Software Number and Version

Menu 0 Notes:

Menu 0 Screen 0 (Home Screen):

Menu 0	Screen	Description
10.0V 5.0A 0.0V 10.0V 10.0A 2.5V	0	Output Voltage, Output Current, Half-Cell Voltage - Actual Values Output Voltage, Output Current, Half-Cell Voltage - Set-Points

The actual values are shown for indication only and are accurate to 2%.

For precise measurements of any value, use a calibrated DVM (and current probe for current).

Active alarms are displayed in sequence on the second line:

Alarms on Line 2	Alarm Full Descriptions
High Out I Alarm	High Output Current Alarm
Low Out I Alarm	Low Output Current Alarm
High Out V Alarm	High Output Voltage Alarm
Low Out V Alarm	Low Output Voltage Alarm
High In V Alarm	High Input Voltage Alarm
Low In V Alarm	Low Input Voltage Alarm
Half-Cell Alarm	Half-Cell Voltage Alarm

Menu 0 Notes:**Menu 0 Screens 1-3 – Set-Points Adjust:**

The Output Voltage and Output Current and Half-Cell Voltage Set-points are easily adjusted using the rotary encoder control to the right of the four keypad switches. Care should be taken that either the Output Voltage Set-point or the Output Current Set-point is set to zero when power is first applied. Then the set-point can be increased and the Output Voltage and Current will increase in sympathy.

If the Half-Cell Voltage Set-point is set to 5.01V then the Controller will operate within the limits set by the Output Voltage and Output Current Set-points.

If the Half-Cell Voltage Set-point is set to a value between 0-5.00V then the Controller will operate in the Half-Cell Control Mode. The rate at which the Controller responds in Half-Cell Control Mode is set by the Half-Cell Control Mode Period (see Menu 4 Screen 7).

Menu 0 Screen 4:

The Input Voltage is shown for indication only and is accurate to 2%.

The status of the Auxiliary Input is shown as Active or Inactive

See Menu 4 Screens 0 and 1 for setting the function of the Auxiliary Input

Menu 0 Screen 5 & 6:

CP Controller Identification and Software:

The CPC Software is used for CPC10A, CPC25A, CPC50A Cathodic Protection Controllers

Screen 5 identifies the Controller Type and System Voltage that has need selected

Screen 6 identifies the Software Number and Version that has been programmed

4.3. Menu 1 – Alarm Settings

Menu 1	Screen	Description
High Out I Alarm Set I: 26.0A	0	High Output Current Alarm Set Current View and adjust parameter
High Out I Alarm Reset I: 24.0A	1	High Output Current Alarm Reset Current View and adjust parameter
High Out I Alarm Delay: 60secs	2	High Output Current Alarm Delay View and adjust parameter: (10 to 240 seconds)
Low Out I Alarm Set I: 1.0A	3	Low Output Current Alarm Set Current View and adjust parameter
Low Out I Alarm Reset I: 3.0A	4	Low Output Current Alarm Reset Current View and adjust parameter
Low Out I Alarm Delay: 60secs	5	Low Output Current Alarm Delay View and adjust parameter: (10 to 240 seconds)
High In V Alarm Set V: 32.0V	6	High Input Voltage Alarm Set Voltage View and adjust parameter
High In V Alarm Reset V: 30.0V	7	High Input Voltage Alarm Reset Voltage View and adjust parameter
High In V Alarm Delay: 60secs	8	High Input Voltage Alarm Delay View and adjust parameter: (10 to 240 seconds)
Low In V Alarm Set V: 20.0V	9	Low Input Voltage Alarm Set Voltage View and adjust parameter
Low In V Alarm Reset V: 22.0V	10	Low Input Voltage Alarm Reset Voltage View and adjust parameter
Low In V Alarm Delay: 60secs	11	Low Input Voltage Alarm Delay View and adjust parameter: (10 to 240 seconds)
Half-Cell Alarm Select: Disable	12	Half-Cell Voltage Alarm Select View and adjust parameter: (Disable or Enable)
Half-Cell Alarm High V: 1.50V	13	Half-Cell Voltage Alarm High Voltage View and adjust parameter
Half-Cell Alarm Low V: 0.85V	14	Half-Cell Voltage Alarm Low Voltage View and adjust parameter
Half-Cell Alarm Delay: 60mins	15	Half-Cell Voltage Alarm Delay View and adjust parameter: (10 to 240 minutes)

Menu 1 Notes: see next page

Menu 1 Notes:**Menu 1 Screens 0-2 – High Output Current Alarms:**

If the Output Current is greater than or equal to the High Output Current Alarm Set Current for the High Output Current Alarm Delay, then the High Output Current Alarm will be activated. If the Output Current is less than or equal to the High Output Current Alarm Reset Current then the High Output Current Alarm will be de-activated.

Menu 1 Screens 3-5 – Low Output Current Alarms:

If the Output Current is less than or equal to the Low Output Current Alarm Set Current for the Low Output Current Alarm Delay, then the Low Output Current Alarm will be activated. If the Output Current is greater than or equal to the Low Output Current Alarm Reset Current then the Low Output Current Alarm will be de-activated.

Menu 1 Screens 6-8 – High Input Voltage Alarms:

If the Input Voltage is greater than or equal to the High Input Volts Alarm Set Voltage for the High Input Volts Alarm Delay, then the High Input Volts Alarm will be activated. If the Input Voltage is less than or equal to the High Input Volts Alarm Reset Voltage then the High Input Volts Alarm will be de-activated.

Menu 1 Screens 9-11 – Low Input Voltage Alarms:

If the Input Voltage is less than or equal to the Low Input Volts Alarm Set Voltage for the Low Input Volts Alarm Delay, then the Low Input Volts Alarm will be activated. If the Input Voltage is greater than or equal to the Low Input Volts Alarm Reset Voltage then the Low Input Volts Alarm will be de-activated.

Menu 1 Screen 12-15 – Half-Cell Voltage Alarms:

The Half-Cell Voltage Alarm must be enabled to be used: Screen 12: Select Enable

If the Half-Cell Voltage is greater than or equal to the Half-Cell Voltage Alarm High Voltage for the Half-Cell Voltage Alarm Delay, then the Half-Cell Voltage Alarm will be activated.

If the Half-Cell Voltage is less than or equal to the Half-Cell Voltage Alarm Low Voltage for the Half-Cell Voltage Alarm Delay, then the Half-Cell Voltage Alarm will be activated.

If the Half-Cell Voltage is greater than the Half-Cell Voltage Alarm Low Voltage and less than the Half-Cell Voltage Alarm High Voltage, then the Half-Cell Voltage Alarm will be de-activated.

4.4. Menu 2 – Interrupt Timer & Output Voltage Alarm Settings

Menu 2	Screen	Description
Int Tim: Disable Output: On 0010	0	Interrupt Timer Status
Int Tim: Disable Select to change	1	Interrupt Timer Status Select View and adjust parameter: (Disable or Enable)
Int Timer change Off Cycle: 0010s	2	Interrupt Timer Off Cycle Time View and adjust parameter
Int Timer change On Cycle: 0010s	3	Interrupt Timer On Cycle Time View and adjust parameter
High Out V Alarm Select: Disable	4	High Output Voltage Alarm Select View and adjust parameter: (Disable or Enable)
High Out V Alarm Set V: 30.0V	5	High Output Voltage Alarm Set Voltage View and adjust parameter
High Out V Alarm Reset V: 28.0V	6	High Output Voltage Alarm Reset Voltage View and adjust parameter
High Out V Alarm Delay: 60secs	7	High Output Voltage Alarm Delay View and adjust parameter: (10 to 240 seconds)
Low Out V Alarm Select: Disable	8	Low Output Voltage Alarm Select View and adjust parameter: (Disable or Enable)
Low Out V Alarm Set V: 20.0V	9	Low Output Voltage Alarm Set Voltage View and adjust parameter
Low Out V Alarm Reset V: 22.0V	10	Low Output Voltage Alarm Reset Voltage View and adjust parameter
Low Out V Alarm Delay: 60secs	11	Low Output Voltage Alarm Delay View and adjust parameter: (10 to 240 seconds)
High In V Alarm Cut Output: No	12	High Input Voltage Alarm Cut Output: View and adjust parameter: (No or Yes)
Low In V Alarm Cut Output: No	13	Low Input Voltage Alarm Cut Output: View and adjust parameter: (No or Yes)
High Out V Alarm Cut Output: No	14	High Output Voltage Alarm Cut Output: View and adjust parameter: (No or Yes)
Low Out V Alarm Cut Output: No	15	Low Output Voltage Alarm Cut Output: View and adjust parameter: (No or Yes)

Menu 2 Notes: see next page

Menu 2 Notes:**Menu 2 Screen 0 – Interrupt Timer Information Screen:**

Line 1: Status of the Interrupt Timer: Enable or Disable.

Line 2: Output: On or Off and a count-down of present Interrupt On or Interrupt Off Time.

Menu 2 Screen 1 – Interrupt Timer Enable / Disable:

The Interrupt Timer is Enabled or Disabled using this screen.

If the Auxiliary Input 1 Function = Interrupt Timer Enable (Menu 4 Screen 0: Auxiliary I/p 1 = Int Timer Enable) then the Interrupt Timer will be Enabled when the Auxiliary Input 1 is Active and it will be Disabled when the Auxiliary Input 1 is In-active.

Menu 2 Screen 2 – Interrupt Timer Off Cycle Time:

The Interrupt Timer Off Cycle Time can be adjusted from 0001 to 9999 seconds.

The CPC Output will be Off during this time.

Menu 2 Screen 3 – Interrupt Timer On Cycle Time:

The Interrupt Timer On Cycle Time can be adjusted from 0001 to 9999 seconds.

The CPC Output will be On during this time.

Menu 2 Screen 4-7 – High Output Voltage Alarms:

The High Output Voltage Alarm must be enabled to be used: Screen 4: Select Enable

If the Output Voltage is greater than or equal to the High Output Voltage Alarm Set Voltage for the High Output Voltage Alarm Delay, then the High Output Voltage Alarm will be activated. If the Output Voltage is less than or equal to the High Output Voltage Alarm Reset Voltage then the High Output Voltage Alarm will be de-activated.

Menu 2 Screen 8-11 – Low Output Voltage Alarms:

The Low Output Voltage Alarm must be enabled to be used: Screen 8: Select Enable

If the Output Voltage is less than or equal to the Low Output Voltage Alarm Set Voltage for the Low Output Voltage Alarm Delay, then the Low Output Voltage Alarm will be activated. If the Output Voltage is greater than or equal to the Low Output Voltage Alarm Reset Voltage then the Low Output Voltage Alarm will be de-activated.

Menu 2 Screen 12-15 – Alarms Functions:

Any of the High or Low Input or Output Voltage Alarms can be used to turn off the output. By default the alarms do not turn off the output. The user can select Yes in order for any of these alarms to turn off the output if the alarm is active.

Menu 2 Screen 12: High Input Voltage Alarm to Cut Output when activated: Select Yes or No

Menu 2 Screen 13: Low Input Voltage Alarm to Cut Output when activated: Select Yes or No

Menu 2 Screen 14: High Output Voltage Alarm to Cut Output when activated: Select Yes or No

Menu 2 Screen 15: Low Output Voltage Alarm to Cut Output when activated: Select Yes or No

4.5. Menu 3 – Alarm Relays

Menu 3	Screen	Description
Relay 1 Function High Out I Alarm	0	Relay 1 Function: View and adjust parameter
Relay 2 Function Low Out I Alarm	1	Relay 2 Function: View and adjust parameter
Relay 3 Function Low In V Alarm	2	Relay 3 Function: View and adjust parameter
Test Relay 1: Press + hold Sel	3	Test Relay 1 Press Select to change the state of the Relay contacts and LED
Test Relay 2: Press + hold Sel	4	Test Relay 2 Press Select to change the state of the Relay contacts and LED
Test Relay 3: Press + hold Sel	5	Test Relay 3 Press Select to change the state of the Relay contacts and LED

Menu 3 Notes:

Menu 3 Screen 0-2 – Alarm Relays Function Descriptions:

Display Text	Full Descriptions
Not Used	No Alarm function programmed
High Out I Alarm	High Output Current Alarm
Low Out I Alarm	Low Output Current Alarm
Low In V Alarm	Low Input Voltage Alarm
Common Alarm	Common Alarm (any active alarm)
System Normal	No active alarm
CP Output Status	Cathodic Protection Output Status
Auxiliary I/p 1	Auxiliary Input 1
High In V Alarm	High Input Voltage Alarm
Half-Cell Alarm	Half-Cell Voltage Alarm
Interrupt Timer	Interrupt Timer Active
High Out V Alarm	High Output Voltage Alarm
Low Out V Alarm	Low Output Voltage Alarm

Menu 3 Screen 3-5 – Test Alarm Relays:

Press Select to change the state of the Relay contacts and LED

4.6. Menu 4 – Miscellaneous

Menu 4	Screen	Description
Auxiliary I/p 1: Not Used	0	Auxiliary Input Function Not Used / Interrupt Timer Enable / Disable Output
Auxiliary I/p 1: Active: Closed	1	Auxiliary Input Volt-free Contact Function: Active Closed or Active Open
Display Power Down: Disable	2	LCD Display Power Down 240s after last keypad switch press: Enable / Disable power down
To Reset Alarms Press --> Select	3	Alarm Reset: Press Select to reset any active alarms Any alarm condition still valid will reactivate after a delay
Restore Factory Defaults --> Sel	4	Restore Factory Defaults Press Select to set all Set-Points back to factory default settings
HalfCell Control Mode Period:1.0s	5	Half-Cell Control Mode Period Select: 0.1, 0.2, 0.5, 1.0, 2.0, 3.0, 4.0, 5.0, 10.0 seconds (default = 1.0s)

Menu 4 Notes:

Menu 4 Screen 0 – Auxiliary Input Function:

Auxiliary I/p 1 = Not Used: The Auxiliary Input has no function

Auxiliary I/p 1 = Int Timer Enable (Interrupt Timer Enable): The Interrupt Timer will be Enabled when the Auxiliary Input is Active and it will be Disabled when the Auxiliary Input is In-active. The Off and On Cycle Times can only be programmed using the Menu 2 Screens 2 & 3 as normal.

Auxiliary I/p 1 = Disable Output: When the Auxiliary Input 1 is Active the CP Output will be Off.

Menu 4 Screen 1 – Auxiliary Input Active Closed or Active Open:

Auxiliary I/p 1 Active = Closed: Auxiliary Input 1 will be Active when the volt-free input is closed

Auxiliary I/p 1 Active = Open: Auxiliary Input 1 will be Active when the volt-free input is open

Menu 4 Screen 2 – LCD Display Power Down:

Display Power Down = Disable: LCD Display is always on

Display Power Down = Enable: LCD Display powers down 240s after the last keypad switch press

Menu 4 Screen 4 – Restore Factory Defaults:

Press Select to restore the factory default values to the CPC Controller.

Menu 4 Screen 5 – Half-Cell Control Mode Period Select:

When the Controller is set to Half-Cell Control Mode, this parameter selects the period of the Half-Cell Control routine. It can be set to 0.1, 0.2, 0.5, 1.0, 2.0, 3.0, 4.0, 5.0 or 10.0 seconds.

Selecting a low value for the period will make the Controller update the output faster.

4.7. Menu 5 – Com Port & Data Log Menu

Menu 5	Screen	Description
Com Port: Micha Function: Comms	0	Communications Port Function: Micha Comms, Type 1 (ADCO), Modbus ASCII, RTU, TCP/IP
Com Port: Address: 001	1	Communications Port Address: View and adjust from 001-247
Com Port: Baud Rate: 9600	2	Communications Port Baud Rate: Select: 9600 or 19200 (Default = 9600)
Data Log: Log Per: 30 mins	3	Data Logging Period: Select: 15 / 30 / 60 / 120 / 180 minutes
Data Log Clock: Set Hours: 12:34	4	Data Logging Clock: Set Hours
Data Log Clock: Set Mins: 12:34	5	Data Logging Clock: Set Minutes
Data Log Clock: Set Date: 01	6	Data Logging Clock: Set Date
Data Log Clock: Set Month: 01	7	Data Logging Clock: Set Month
Data Log Clock: Set Year: 2017	8	Data Logging Clock: Set Year
Date log: Write 1 Record --> Sel	9	Write 1 Record to the Data Log every time Select is pressed (used for testing purposes)
Data Log: Select: Enable	10	Data Log Status: Enable / Disable: Press Select to toggle the Data Logger Status (Default = Enable)

Menu 5 Notes:

Menu 5 Screen 0 – Com Port Function:

The Com Port Function selects the response protocol of the Controller. The Controller can respond with Micha Comms, Type 1 (ADCO Comms), Modbus ASCII Slave, Modbus RTU Slave, Modbus TCP/IP Slave. (Default = Micha Comms)

See Micha Document 801779 for the CPC Modbus Memory Map

Menu 5 Screen 1 – Com Port Address:

The Com Port Address must match the received message for the controller to respond. For a system with more than one controller, then each Controller Com Port must be set with a unique Com Port Address.

Menu 5 Screen 2 – Com Port Baud Rate:

The Com Port Baud Rate can be set to either 9600 or 19200 Baud.

4.8. Menu 6 – Program 4-20mA Outputs (if fitted)

Menu 6	Screen	Description
Program 4-20mA Outputs	0	Menu Identification
4-20mA O/p 1: Output: Output V	1	4-20mA Output 1: Select Parameter for 4-20mA Output
4-20mA O/p 1: OV 4mA => 0.0V	2	4-20mA Output 1: Select Value for 4mA Output
4-20mA O/p 1: OV 20mA => 30.0V	3	4-20mA Output 1: Select Value for 20mA Output
4-20mA O/p 2: Output: Output I	4	4-20mA Output 2: Select Parameter for 4-20mA Output
4-20mA O/p 2: OI 4mA => 0.0A	5	4-20mA Output 2: Select Value for 4mA Output
4-20mA O/p 2: OI 20mA => 25.0A	6	4-20mA Output 2: Select Value for 20mA Output
4-20mA O/p 3: Output: HalfCell	7	4-20mA Output 3: Select Parameter for 4-20mA Output
4-20mA O/p 3: HC 4mA => 0.00V	8	4-20mA Output 3: Select Value for 4mA Output
4-20mA O/p 3: HC 20mA => 5.00V	9	4-20mA Output 3: Select Value for 20mA Output

Menu 6 Notes:

The CPC Controller can have up to three 4-20mA Outputs:

Menu 6 Screens 1-3 select the parameters for 4-20mA Output 1

Menu 6 Screens 4-6 select the parameters for 4-20mA Output 2

Menu 6 Screens 7-9 select the parameters for 4-20mA Output 3

For each 4-20mA Output:

Select the parameter: Output Voltage / Output Current / Half-Cell Voltage / Input Voltage

Select the parameter value to be represented by 4mA

Select the parameter value to be represented by 20mA

4.9. CPC Parameters – Factory Defaults

Parameter Description	Factory Default Setting
Output Voltage Set-point	0.0V
Output Current Set-point	CPC10A = 10.0A, CPC25A = 25.0A, CPC50A = 50.0A
Half-Cell Voltage Set-point	5.0V
High Output Current Alarm Trip Level	CPC10A = 11.0A, CPC25A = 26.0A, CPC50A = 51.0A
High Output Current Alarm Reset Level	CPC10A = 9.0A, CPC25A = 24.0A, CPC50A = 49.0A
High Output Current Alarm Delay	60 seconds
Low Output Current Alarm Trip Level	CPC10A = 0.5A, CPC25A = 1.0A, CPC50A = 1.0A
Low Output Current Alarm Reset Level	CPC10A = 2.0A, CPC25A = 3.0A, CPC50A = 3.0A
Low Output Current Alarm Delay	60 seconds
High Input Voltage Alarm Trip Level	12V Unit = 16.0V, 24V=32.0V, 36V=48.0V, 48V=64.0V
High Input Voltage Alarm Reset Level	12V Unit = 15.0V, 24V=30.0V, 36V=45.0V, 48V=60.0V
High Input Voltage Alarm Delay	60 seconds
Low Input Voltage Alarm Trip Level	12V Unit = 10.0V, 24V=20.0V, 36V=30.0V, 48V=40.0V
Low Input Voltage Alarm Reset Level	12V Unit = 11.0V, 24V=22.0V, 36V=33.0V, 48V=44.0V
Low Input Voltage Alarm Delay	60 seconds
Half-Cell Voltage Alarm	Disabled
Half-Cell Voltage Alarm Trip Level	1.50V
Half-Cell Voltage Alarm Reset Level	0.85V
Half-Cell Voltage Alarm Delay	60 minutes
Interrupt Timer: Enabled/Disabled	Disabled
Interrupt Timer Off Cycle Time	10 seconds
Interrupt Timer On Cycle Time	10 seconds
High Output Voltage Alarm Enable	Disabled
High Output Voltage Alarm Trip Level	12V Unit = 15.0V, 24V=30.0V, 36V=45.0V, 48V=60.0V
High Output Voltage Alarm Reset Level	12V Unit = 14.0V, 24V=28.0V, 36V=42.0V, 48V=56.0V
High Output Voltage Alarm Delay	60 seconds
Low Output Voltage Alarm Enable	Disabled
Low Output Voltage Alarm Trip Level	12V Unit = 10.0V, 24V=20.0V, 36V=30.0V, 48V=40.0V
Low Output Voltage Alarm Reset Level	12V Unit = 11.0V, 24V=22.0V, 36V=33.0V, 48V=44.0V
Low Output Voltage Alarm Delay	60 seconds
Alarm Relay 1 Function	High Current Alarm
Alarm Relay 2 Function	Low Current Alarm
Alarm Relay 3 Function	Low Input Voltage Alarm
Auxiliary Input Function	Not used
Auxiliary Input Volt-free Contact Function	Active Closed
LCD Display Power Down	Disabled
Half Cell Control Mode Period	1.0 second
Communications Port Function	Micha Comms
Communications Port Address	001
Communications Port Baud Rate	9600
Data Logging: Enabled / Disabled	Enabled
Data Logging Period	30 minutes

4.10. Data Logging Information

Data Log Records

The Data Log holds information about the operation of the Controller in non-volatile memory (i.e. the information is retained when power is lost).

The Data Log consists of various Data Records that are a “snapshot” of the operation of the Controller and contain information such as: time, alarm status, interrupt timer status, output status, output voltage and current etc.

Timed Data Records:

The unit can be set to create a Timed Data Record every 15, 30, 60, 120 or 180 minutes.

The unit will create a Timed Data Record when power is applied to the unit.

The unit will create a Timed Data Record after the Data Log is cleared.

The unit can record up to 10,208 Timed Data Records.

Alarm Data Records:

The unit will create an Alarm Data Record when an Alarm changes state (either becomes active or inactive).

The unit will create an Alarm Data Record when the Interrupt Timer is started and stopped. (This is an ‘advisory’ warning only as some standard alarms - such as the Low Output Current Alarm - will NOT be activated.)

The unit can record up to 2048 Alarm Data Records

Data Log Memory

The Data Log Memory has a maximum size as stated above. The Data Log Memory acts as a First In First Out (FIFO) type of memory. When the memory is full, new Data Records are written over the oldest records so the Data log contains the last so many days worth of data.

The table below states the nominal Data Log Memory Capacity based on 10,208 Timed Data Records:

Data Logging Period	15 minutes	30 minutes	60 minutes	120 minutes	180 minutes
Records per day	96 records	48 records	24 records	12 records	8 records
Memory Capacity	106 days	212 days	425 days	850 days	1276 days

Data Log Downloading

The Data Log may be downloaded to a PC or laptop at any time.

The downloading operation does NOT erase the data in the Data Log, erasing the Data Log is a separate operation only available through the communications port.

5. Software

5.1. Software History

Software Version	Date Released	Description
802 014 Ver 2.0	14 July 2017	New document started
802 014 Ver 2.1	15 Sept 2017	Add Voltage, Current & Half-Cell Output Voltage Control Modify to allow Modbus Poll and Mdbus to work
802 014 Ver 2.2	13 April 2018	Add Modbus CPC Output Disable/Enable Command Add Modbus Common Alarm Read
802 014 Ver 2.3	03 May 2018	Modbus RTU responses added Logging Period (added 120 & 180 minutes), 36V option added
802 014 Ver 2.4	18 Jan 2021	Modbus TCP responses added
802 014 Ver 2.5	10 Feb 2022	Add Configuration Option of Limited Output Voltage or Current Add Configuration Screen 4
802 014 Ver 2.6	12 May 2022	Corrected software bug: when power to CPC removed and reapplied, the Output Current Setpoint would revert to 20A. Issue solved.
802 014 Ver 2.7	05 May 2026	Add Com Port Baud Rate selection to Menu 5 Remove old Modem selection screens from Menu 4

5.2. Installation / Replacement of the MCU

Ensure that anti-static precautions are taken to avoid damage to the Micro-controller when handling (i.e. touch a conductor that is connected to earth before carrying out the following):

Turn off all power to the CPC Controller by turning off the output MCB of the connected charge controller.

Remove CPC Control PCB Fascia Cover using the four plastic thumbscrews. Identify the Microcontroller - IC21 (40 pin integrated circuit) on the PCB Assembly. Carefully lever out the Microcontroller presently located there by using a small flat screwdriver on both ends equally. Do this carefully.

Identify the device to be installed. Carefully handle the device without touching the legs of the device. NOTE the orientation of the semi-circular notch out of one end of the device. NOTE which end of IC21 has a notch in the PCB socket. Now insert the Microcontroller into the IC21 socket so that the notch in the device is at the same end as the notch in the socket. Before pressing down on the device to mate it fully in its socket, check that all pins are properly lined up with the pins in the PCB socket. Press the device fully into the socket and check that no leg has been bent or missed its socket.

Replace CPC Control PCB Fascia Cover using the four plastic thumbscrews. Restore power to the CPC Controller by turning on the output MCB (if fitted) of the connected charge controller.

NOTE:

Later versions of the CPC Control PCB Assembly have a software program port (J4 = PROG) which can be used with the Microchip PICKit3, PICKit4 or PICKit5 Programmer and the Microchip IPE (Integrated Programming Environment) to program the Microcontroller while it remains installed on the PCB Assembly.

6. Document Revision

Issue	Date Released	Description
2.0	14 July 2017	New document started
2.1	03 May 2018	Modbus RTU responses added Logging Period expanded, 36V option added
2.2	01 July 2020	Explanation of Half-Cell Control Mode (Menu 0 Screen 3) And Half-Cell Control Mode Period (Menu 4 Screen 7)
2.3	18 Jan 2021	Modbus TCP responses added (Menu 5 Screen 0)
2.4	05 May 2026	Add Com Port Baud Rate selection to Menu 5