GPS Interrupter Module – PN's 103391 & 103392
GPS Antenna PN - 103 274

The **Michā** GPS Interrupter Module is designed to interface directly with the Michā range of CP Controllers, and can also be used as a stand-alone, programmable interrupter with other equipment. Two outputs are available; an optically isolated switch rated at 70V/50mA, and a MOSFET, rated at 100V/2A. GPS is used to provide an extremely accurate UTS time which allows a number of separate modules to be synchronised with each other. An antenna is essential to receive satellite data, and this should be positioned externally for optimal signal strength, ideally away from metal structures.

Main Features:

- GPS Accuracy ($\pm 3\text{mS}$)
- 10-30VDC & 20-60VDC versions
- Low Power: approx. 0.35W/24V
- -5°C to $+55^{\circ}\text{C}$ operating range
- 30 Programmable Sequences
- Non-volatile Memory
- Opto-isolated output
- Switched power output
- Alphanumeric LCD display
- LED status indicators
- DIN-rail mounting
- 106mm x 90mm x 45mm

LED Indicators:

Blue: Steady when power is first applied. Flashes at 1Hz when satellite synchronisation is achieved with UTC, Latitude and Longitude data received.

Green: Steady when a future program is in memory. Flashes at 1Hz when running a Program.

Red: Illuminated to indicate the output is Active / ON.

General Specification:

Module size:	106 x 90 x 45mm (excluding SMA connector) DIN-rail clip on rear fits standard 35mm 'top hat' profile (TS35 DIN 46277) Enclosure material: Self-extinguishing PC/ABS UL94-VO Colour: RAL 7035
Module weight:	0.2kg (Antenna PN 103274: 0.08kg)
Power consumption:	25-30mA @ 12VDC 12-15mA @ 24VDC 5-7mA @ 48VDC (all nominal)
Part Numbers:	103391: Supply voltage 10-30VDC 103392: Supply voltage 20-60VDC
Manufacturer	The Michā Design Company Limited
Country of Origin / HS Code	United Kingdom / HS Code: 90328900

<u>Using the GPS Interrupter</u>		
Operation	LED	LCD Display
<p>Power Up</p> <p>The display shows a default time and date as shown. With a good GPS signal, the UTC time will appear within around 30 seconds, and GPS synchronisation within 60 seconds. When synchronised, the blue LED flashes at 1Hz and the * symbol appears on the display.</p> <p>By default, the time and date are shown.</p>	<p>● — ○ ○</p> <p>● -- ○ ○</p>	<div style="border: 1px solid black; padding: 5px; text-align: center;"> <p>10:00:00 01-Jan-2001</p> </div> <div style="border: 1px solid black; padding: 5px; text-align: center; margin-top: 10px;"> <p>UTC: 15:04:17 * 19-May-2026</p> </div>
	<p>● -- ● -- ● --</p>	<p>When a program is running, the bottom line of the LCD display alternates between showing the date and the number of the Program that is running.</p>
<p>Press UP:</p> <p>Display will show the Menu number: (Press MENU & DOWN to get here)</p>		<div style="border: 1px solid black; padding: 5px; text-align: center;"> <p>**** Menu 0 **** Information</p> </div>
<p>Press DOWN:</p> <p>Display shows Latitude & Longitude: (Satellite synchronisation required.)</p>	<p>● -- ○ ○</p>	<div style="border: 1px solid black; padding: 5px; text-align: center;"> <p>Lat: 51°49'19.1N Lon:000°49'85.2W</p> </div>
<p>Press DOWN:</p> <p>SELECT > GPS Interrupter Output ON. If it's already ON (active), the output does not change</p>	<p>● -- ○ ●</p>	<div style="border: 1px solid black; padding: 5px; text-align: center;"> <p>Test Output: Press --> Select</p> </div>
<p>Press DOWN:</p> <p>SELECT > Reset all programs > It will ask: "Are you sure?" SELECT > to confirm</p>		<div style="border: 1px solid black; padding: 5px; text-align: center;"> <p>Reset Programs: Press --> Select</p> </div>
<p>Press DOWN:</p> <p>SELECT > Modbus ASCII or RTU</p>		<div style="border: 1px solid black; padding: 5px; text-align: center;"> <p>Com Port: Modbus Function: RTU</p> </div>
<p>Press DOWN:</p> <p>SELECT > Adjust Com Port Address / Slave ID from 001 to 247</p>		<div style="border: 1px solid black; padding: 5px; text-align: center;"> <p>Com Port Address Slave ID: 001</p> </div>
<p>Press DOWN:</p> <p>SELECT > Adjust Com Port Baud Rate: 9600 (default) or 19200</p>		<div style="border: 1px solid black; padding: 5px; text-align: center;"> <p>Com Port: Baud Rate: 9600</p> </div>
<p>Press DOWN:</p> <p>Software Number & Version is shown</p>		<div style="border: 1px solid black; padding: 5px; text-align: center;"> <p>Software: 802537 Ver 1.2</p> </div>

Note: In the event the GPS signal is lost after GPS synchronisation, the module will continue to run on its internal clock, with an accuracy of approximately ± 1 s per day. However, the '*' symbol will disappear from the display, and the blue LED will be illuminated continuously.



Setting up a Program		
Procedure	LED	LCD Display
<p>Menu 1 From Menu 0, press MENU to get to Program 1.</p> <p>Notes:</p>		<div style="border: 1px solid black; padding: 5px; text-align: center;"> **** Menu 01 *** Program 01 </div>
<p>Times shown refer to the GPS time, which is UTC. Although it is possible to program a time and date in the past, these sequences will be ignored.</p>	<p>Press DOWN: the display will show the Program Status. Press UP or DOWN to toggle the status, press SELECT to store in memory. Status <u>must</u> be set to Disable to allow changes to any of the following settings.</p>	<div style="display: flex; align-items: center;"> <div style="margin-right: 10px;"> <p>● --</p> <p>○</p> <p>○</p> </div> <div style="border: 1px solid black; padding: 5px; text-align: center;"> Program 01 Status: Disable </div> </div>
<p>After <u>any</u> change, press SELECT to confirm and store the entry.</p>	<p>Press DOWN again: to set the Program Start time and date, press SELECT and the 'hours' field will start flashing. Press the UP and DOWN keys to select the required hours. Press SELECT again to move on to the next field.</p> <p>Continue until all fields are updated and the display shows the required Program Start time and date:</p>	<div style="display: flex; align-items: center;"> <div style="margin-right: 10px;"> <p>● --</p> <p>○</p> <p>●</p> </div> <div style="border: 1px solid black; padding: 5px; text-align: center;"> Program 01 Start 12:00 01-Jan-26 </div> </div> <div style="border: 1px solid black; padding: 5px; text-align: center;"> Program 01 Start 15:30 19-May-26 </div>
<p>Maximum Run Time: 23hrs 59mins.</p>	<p>Press DOWN again and press SELECT to set the Run time (Program duration from starting).</p>	<div style="border: 1px solid black; padding: 5px; text-align: center;"> Program 01 hh:mm RUN Time: 01:00 </div>
<p>ON time can be set to any value between 0.2s and 99.9s</p>	<p>Press DOWN again and press SELECT to set the ON time (output is Active)</p>	<div style="border: 1px solid black; padding: 5px; text-align: center;"> Program 01 ON Time: 10:0s </div>
<p>OFF time can be set to any value between 0.2s and 99.9s</p>	<p>Press DOWN again and press SELECT to set the OFF time (output is inactive).</p>	<div style="border: 1px solid black; padding: 5px; text-align: center;"> Program 01 OFF Time: 10:0s </div>
<p>The Output can be set to start the Program with the output ON or OFF.</p>	<p>Press DOWN again and press SELECT to alter if the Program should start with the ON period or the OFF period.</p>	<div style="border: 1px solid black; padding: 5px; text-align: center;"> Program 01 Output Start:ON </div>
<p>** Remember to now Enable the Program if you wish it to run. **</p>		
<p>Programs can be entered with a Start date and time in any order.</p>	<p>If an additional future program is required, press MENU to go to the next program.</p>	<div style="border: 1px solid black; padding: 5px; text-align: center;"> **** Menu 02 *** Program 02 </div>

Programs are retained in memory during power loss, but if power is lost mid-program, when power returns the program will not restart. Before a GPS time signal is obtained, the green LED may be temporarily illuminated to indicate a stored, enabled program with a start date later than the default.



Running a Program

Procedure	LED	LCD Display
<p>Note: The software scans all of the Enabled Programs in order from 1 to 30. If a Program Start Time matches UTC time, this Program will start and all other programs will be ignored until the Program has ended</p>		
<p>Menu 0</p> <p>If any Program is set to commence in the future, the green LED will be illuminated constantly.</p> <p>Note: When a Program is running, it is still possible to manually activate the output using the 'Test Output' function.</p>	<p>● -- ● -- ○</p> <p>● -- ● -- ●</p>	<div style="border: 1px solid black; padding: 5px; margin-bottom: 5px;"> UTC: 15:04:18 * 19-May-2026 </div> <div style="border: 1px solid black; padding: 5px;"> UTC: 15:30:18 Prog 1 Running </div>
<p>When a Program starts, the green LED will flash and the main display will alternate between showing the date and the Program that is running. The red LED will be illuminated when the output is ON.</p>		

Terminals and connections:

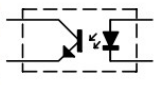
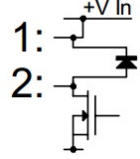
<u>POWER IN</u>	<u>OPTO SW.</u>	<u>RELAY SW.</u>	<u>RS485</u>
3: V+ 4: V- 1: Power in +V 2: Power In -V 10-20VDC or 20-60VDC (internally fused)	 8: Opto-switch +V 9: Opto-switch -V Connect to the Disable input of the Micha CPC. Can be used as VFC contact to other equip.	 1: +V (fused V+ in) 2: Switched -V to V- in (Internal flyback diode across 1 & 2) These terminals can be used to switch an external contactor. Max. current: 2A	5: A 6: B 7: COM 5: RS485 "A" 6: RS485 "B" 7: RS485 "COM"
All terminals: plug and socket type, rising clamp, max. cable: 2.5mm². Antenna: SMA female.			
Fuse: The module and switched output (terminals 1 & 2) are protected by a 2A (max) 20mm fuse.			
VR1: Potentiometer VR1 – fitted by the fuse – can be used to adjust the contrast of the LCD display.			

Terminology:

Program: A sequence of ON and OFF times which activate (ON time) and deactivate (OFF time) the GPS Interrupter Output. Each Program has a Start time, a Run time, and the Program can start with the Output ON or OFF

Output: The GPS Interrupter Output will be 'Active' during the ON time, and inactive during the OFF time. Where an output is described as 'Active' or 'ON', it means that the module outputs are switched on and a connected CP Controller is considered to be DISABLED, or 'Interrupted'.

Document History:	Date:	Software:	Notes:
802535 Issue 1	08-Jun-2018	802537 V1.0	First issue
802535 Issue 2	10-Sep-2020	802537 V1.0	Clarifications of GPS usage
	08-Aug-2018	802537 V1.1	Added Modbus ASCII & RTU
802535 Issue 3	19-May-2026	802537 V1.2	Added Com Port Baud Rate Selection